

PART NAME PLASTIBOX (STYLE F)

PART No. PS-11521

MATERIAL: HIGH-IMPACT ABS
 COLOR: BLACK OR GRAY
 FINISH: TEXTURED BODY WITH
 SMOOTH TOP INSERT

FOUR (4) #4 x 1/4 LG. SCREWS
 SUPPLIED FOR ASSEMBLING TOP.

FOUR (4) NON-SKID PUSH-ON FEET SUPPLIED

*-USABLE AREA ON TOP ALSO
 AVAILABLE FOR CUSTOM MOLDING.

NOTE: ALL DIMENSIONS HAVE ±0.015 TOLERANCE
 UNLESS OTHERWISE SPECIFIED.

MOUNTING BOSSES USE EITHER M2.5 METRIC
 OR #4 STD. SHEET METAL SCREWS
 x 3/16 LG. (NOT SUPPLIED)

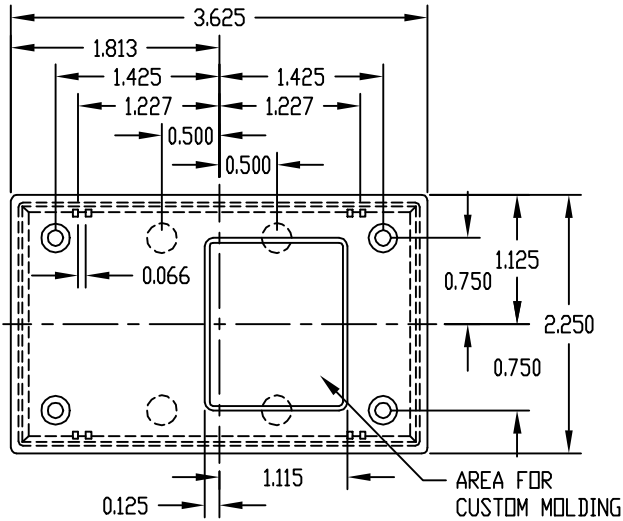
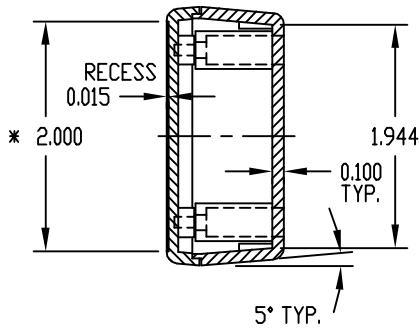
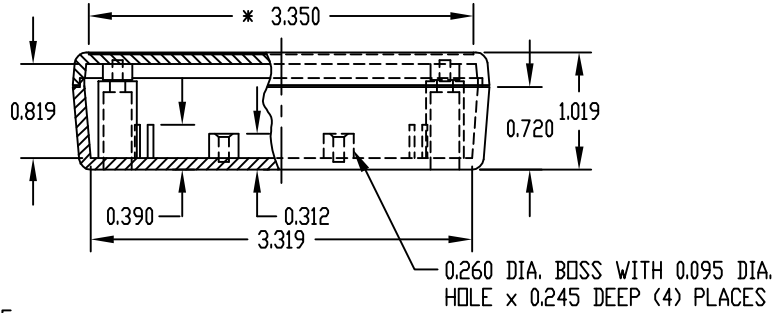

PART NAME PLASTIBOX (STYLE F) W/BATTERY COMPARTMENT

PART No. PBS-11532

MATERIAL: HIGH-IMPACT ABS
 COLOR: BLACK OR GRAY
 FINISH: TEXTURED BODY WITH
 SMOOTH TOP INSERT

9V BATTERY
 COMPARTMENT

FOUR (4) #4 x 3/8 LG. SCREWS
 SUPPLIED FOR ASSEMBLING TOP.

FOUR (4) NON-SKID PUSH-ON FEET SUPPLIED

*-USABLE AREA ON TOP ALSO
 AVAILABLE FOR CUSTOM MOLDING.

NOTE: ALL DIMENSIONS HAVE ±0.015 TOLERANCE
 UNLESS OTHERWISE SPECIFIED.

MOUNTING BOSSES USE EITHER M2.5 METRIC
 OR #4 STD. SHEET METAL SCREWS
 x 3/16 LG. (NOT SUPPLIED)

